

EUROVIEW

FRAMELESS GLASS ENCLOSURES

Installation Instructions

Model **IMT-3/IMS-3**

When ordering repair parts,
please give the following
information:

1. Model Number
2. Part Number
3. Part Description
4. Color

Frameless Bypass Tub / Shower Enclosure

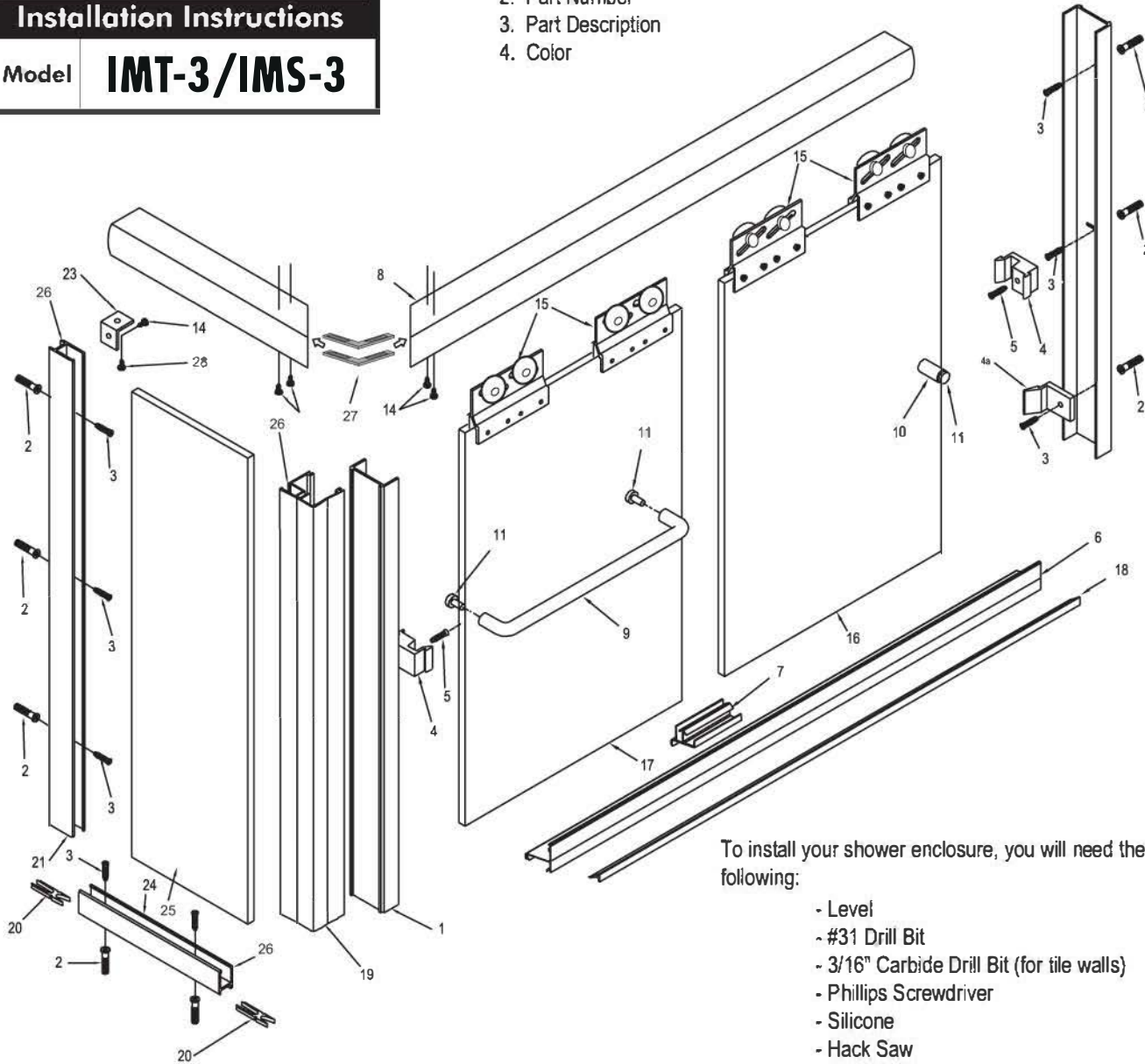

To install your shower enclosure, you will need the following:

- Level
- #31 Drill Bit
- 3/16" Carbide Drill Bit (for tile walls)
- Phillips Screwdriver
- Silicone
- Hack Saw
- 1/4" Box End Wrench

Description	Qty	Part No.	
1. Wall Jamba	2	ZTE-1203	
2. Wall Anchors	8	ZV-935	
3. #8 x 1 1/4" Screws		#8 x 1-1/4"	
4. Door Bumpers	2	ZV-924	
4a. Bottom Bumper	1	ZV-926	
5. 8-32 x 1/2" Screw	2	8-32 x 1/2"	
6. Bottom Sill	1	ZTE-1222	
7. Center Guide - 3"	1	ZV-920	
8. Header - Mitered	2	ZTE-1601	
9. Solid Tubular Towel Bar	1	ZTE-1605	
10. Solid Tubular Inside Pull	1	ZTE-1605-K	
11. Towel Bar Pull Fastener	3		
12. Nylon Towel Bar Washer	6	3/4" nylon washer	
13. Nylon Towel Bar Sleeve	3	1/4" nylon sleeve	
14. #6 x 3/8" Screw	7	#6 x 3/8"	
15. Double Roller Bracket Assem. -3"	4	ZTE-1208D	
16. Inside 1/4" Glass Panel with one 1/2" hole	1	Inside Slider 3/8"	
17. Outside 1/4" Glass Panel with two 1/2" holes	1	Outside Slider 3/8"	
18. Door Guide Vinyl with ZTE-1222	1	ZV-918	
19. 90-Degree Post	1	ZTE-1214	
20. Cub Channel	1	ZD-1006	
21. Wall Channel	2	ZD-1006	
22. Post To Cub Key	2	ZC-180	
23. Clip	1	ZD-90	
24. Glass Support Block	1	ZV-902	
25. 90-Degree Glass Panel	1		
26. Vertical Seal Vinyl	6	ZV-909	
27. 90 Degree Header Clip	2	ZA-90	
28. #6 x 1/4 screw	1		

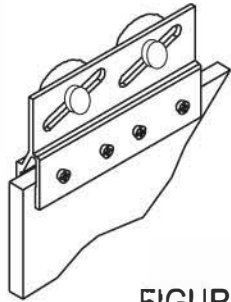

FIGURE 1

Note: Apply a bead of silicone (GE1200) into the open channel of roller bracket before attaching to glass. To assemble roller bracket (15) to glass, tighten screw until surface of roller bracket is depressed by 1/32" (28 inch pounds of torque). Allow silicone to cure for 24 hours before hanging sliders.

- Using a straight edge, draw a line down the center of the tub rim or pan curb. (The lines should cross in the center of the front corner).
- Set Jamb (1) in place on wall, centering bottom of jamb on rim of tub. Hold plumb and mark for screw holes.
- Remove jamb (1) and drill 3/16" holes and insert plastic screw anchors (2).

- Silicone where the wall meets the rim of the tub to seal bottom corner of jamb. Set jamb (2) in place and secure with #8 x 1-1/4 screws (3). Secure bottom bumper (4a) on shower head side with bottom jamb screw.

- Measure, on end panel side, from back wall to center of front corner where lines cross. Deduct 3/4" from this measurement and cut curb channel (20) to length. Run a bead of silicone on underside of curb channel and set curb channel in place on center of curb. (Weep holes to inside). Slide post to curb key (22) onto curb channel (20) and move to the wall. Vertical wall channel will key over exposed end.

- Set wall channel (21) on curb channel, hold plumb and mark the wall for the screw hole locations. Remove wall channel, drill holes into the wall and insert plastic anchors. Fill curb channel with silicone where curb channel meets wall. Set wall channel in place and secure with #8 x 1-1/2" screws (3). Secure header clip (23) to top inside leg of wall channel with #6 x 3/8" screw (25).

- Place glass support block (24) in center of the curb channel. Set panel (26) into place in curb channel and into wall channel. Using the vertical seal vinyl (27) into wall channel on both sides of the panel.

FIGURE 2

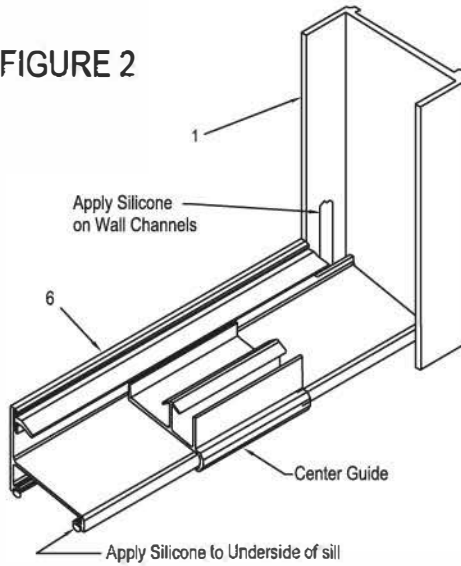

- Insert clip (22) into curb channel and apply a layer of silicone to curb where 90 post will set. Set corner post (19) in place over edge of panel glass and curb clip, hold plumb and insert vertical seal vinyl (27) into post and curb channel on both sides of panel glass.

- Measure from inside of wall jamb to inside of 90 post and use this measurement to cut sill (6) to length. Run a bead of silicone full length to underside of sill and apply silicone in corners where wall jamb and corner post meet curb and press guide firmly into place on curb (See Figure 2).

- Assemble header (8) using 90 clips (28) and #6 x 3/8" SMS (14). Measure from both walls to outside corner of corner post (plumb in both directions) and add 3/16" to this measurement for header length. Cut header to length and set in place over jamb (1), corner post (19) and wall channel (21). Secure header to jamb and corner post from inside of shower and to clip (23) attached to wall channel with #6 x 3/8" SMS.

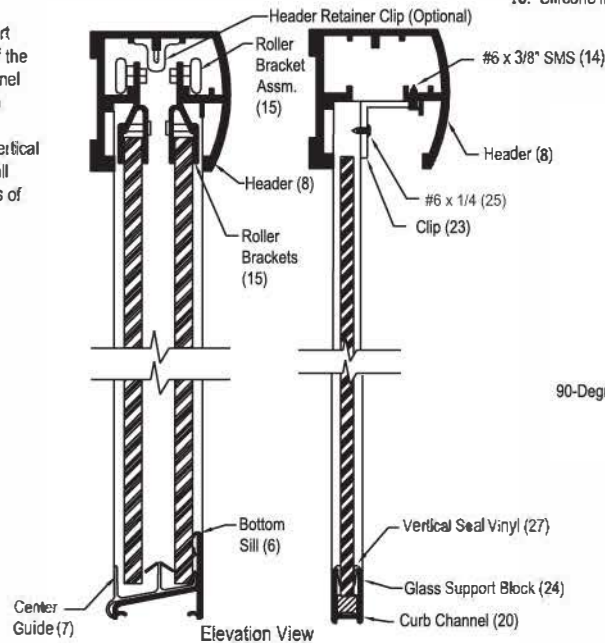
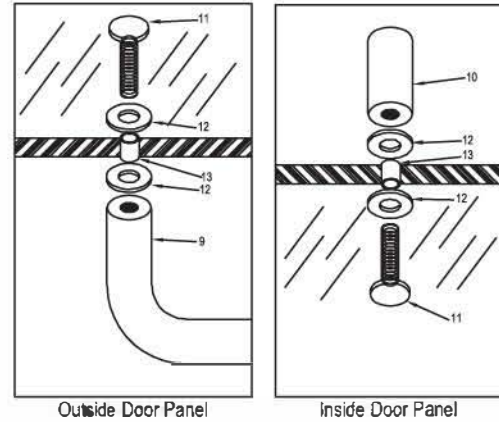

FIGURE 3



- Close panels and adjust to align the vertical edge of panels with jamb and post. Using a 1/4" box-end-wrench, loosen the screws on the rollers, but don't remove completely. When screws are loose, adjust panel by sliding the screw in the slot. **NOTE:** when screws are loose be sure to support panel so it does not fall and break. Adjust inside slider as low as possible to reduce the gap between bottom of slider and sill taking care that the glass does not drag on the track or center guide. Adjust for bowed glass by using the slotted hole in the jamb.

- Install bumpers (4) to the jambs and corner post with 6-32 x 1/2" screw (5). **NOTE:** Glass panels close into the recessed portion of Bumpers (4). The recess is toward the inside of the tub on the shower head jamb and toward the outside on the corner post.

- To install towel bar (9), place nylon towel bar inser sleeves (13) into holes in the glass (17). Next hold the tubular towel bar (9) against the hole in the glass with the nylon towel bar/pull washer (12) between the glass and the towel bar. Place a nylon towel bar/pull washer on the towel bar/pull screw (11) and secure towel bar in place on both ends. Install the pull the same way the towel bar was installed. Use hole in fastener to tighten (See Figure 3).

- Silicone inside of shower where jambs meet walls and sill meets rim of tub.

FIGURE 4

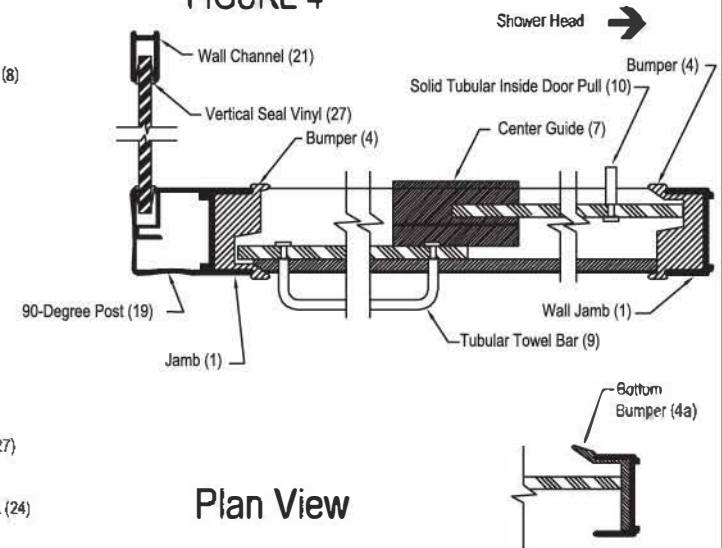

Plan View