

# EUROVIEW

FRAMELESS GLASS ENCLOSURES

## Installation Instructions

Model

**MST**

When ordering repair parts, please give the following information:

1. Model Number
2. Part Number
3. Part Description
4. Color

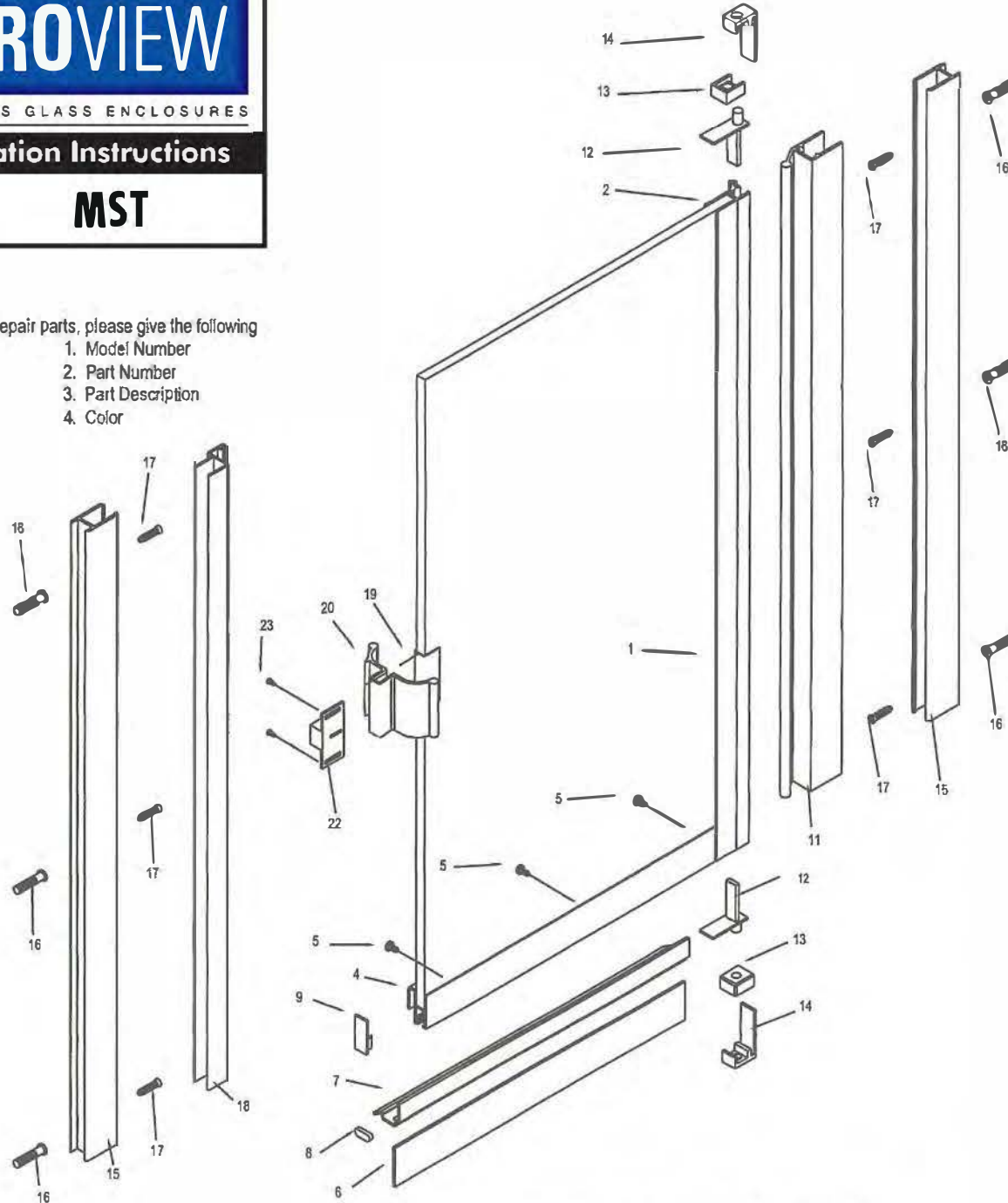

## INSTALLATION INSTRUCTIONS MST

To assemble your shower enclosure, you will need the following:

- Phillips Screwdriver
- Silicone
- Hack Saw
- Glazing Block
- Hammer
- Side Cutters

Description	Qty	Part No.	Picture
1. Glazing Vinyl	1	ZV-925	
2. Hinge Rail with Vinyl	1	ZD-2503	
3. Glazing Vinyl	1	ZV-903	
4. Bottom Rail	1	ZD-2002	
5. #5 x 1/4" Screws	3	#5 x 1/4	
6. Splash Vinyl	1	ZV-904	
7. Drip Trough	1	ZD-1008	
8. Drip Plug	1	ZV-905	
9. Bottom Rail End Cap	1	ZV-940	
10. Hinge Jamb Sleeve Vinyl	1	ZV-955	
11. Hinge Jamb	1	ZD-2505	
12. Hinge Pins	2	ZV-945	
13. Hinge Bushings	2	ZD-1013	
14. Hinge Clips	2	ZD-1009	
15. Wall Channels	2	ZD-1006	
16. Wall Anchors	6	ZV-935	
17. #8 x 1 1/2" Screws	6	#8 x 1 1/2	
18. Latch Jamb w/ V-905 Vinyl	1	ZD-1004	
19. 3" Handle Vinyl	1	ZV-914	
20. 3" Door Pull			
21. #6 x 3/8" Screws	6	#6 x 3/8	
22. Box Catch			
23. 6-32 x 3/16" Screws			
24. #8 x 1 1/2" FH Screw	1	#8 x 1 1/2	
<u>Optional Mag Catch</u>			
20. 3" Mag Door Pull	1	MAG 4011.3	
22. Mag Channel	1		
23. #6 x 1/4"	2	#6 x 1/4	

MST Assembly Instructions

Figure 1

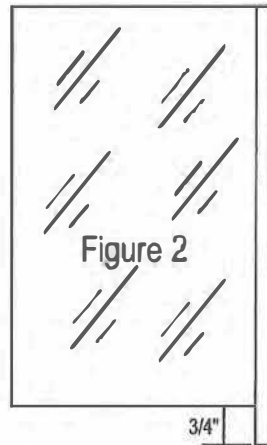
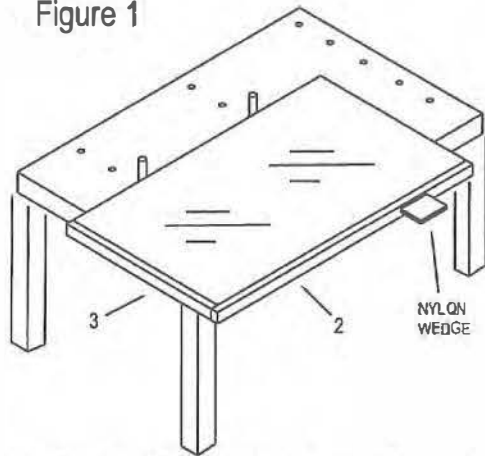

**Note:** Assembly of a hinge-right door is shown in Figure 1. For a hinge-left door, place bottom rail assembly at opposite end.

1. Lay glass flat, smooth side up on assembly table (Figure 1) and bracing glass on far side as shown so hinge rail can be driven into place. Apply glazing channel (1) to one long, and short edge of glass.

2. Hold the hinge rail (2) in place against vinyl channel with 3/4" extending beyond end of glass, at bottom (see Figure 2). Using a block of hardwood and a heavy steel hammer, drive hinge rail into place on glass.

**Note:** The tolerances on glass, aluminum and vinyl may cause the hinge rail to fit too tight to drive on. In this case with a small paint brush (a small foam paint brush works well here) apply a very weak solution of liquid soap and water to the inside of the hinge rail. DO NOT use other types of lubricant or allow lubrication to get in between vinyl and glass because this may cause the glass to slide down or out of the hinge rail.

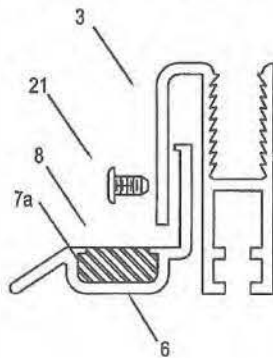
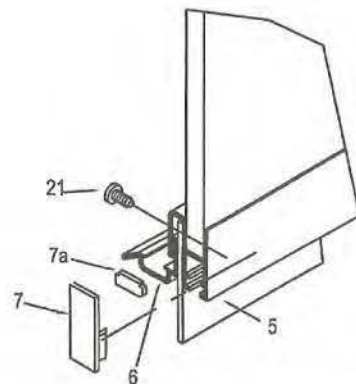
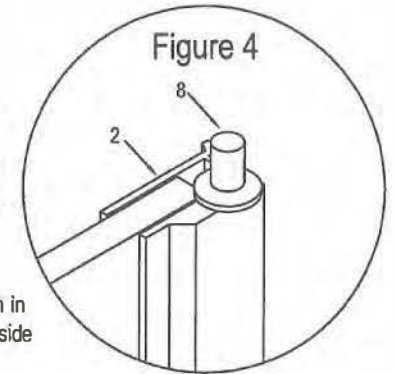

Figure 3



3. Hold bottom rail (3) in place against vinyl channel and drive into place on glass using the block of wood and hammer described above. Start three 6/32 x 3/16" screws (21) into bottom rail. Insert splash vinyl (5) and drip trough (6) into bottom rail (see Figure 3) and secure by tightening the three 6/32 x 3/16" screws (21). Keep end of drip trough 3/8" in from latch side of door. Insert drip plug (7) into end of drip channel opposite the hinge rail side.

**Note:** Drip trough should be installed so it is flush with notch in bottom rail (See Figure 3) and slopes down at the hinge rail side so water will drain back into shower when door is open.



4. Drive hinge pins, the end of pin with id. circle (8) into ends of hinge rail. Assemble hinge clips/bushings (9&11) and then insert into hinge jamb (10) See Figures 4 & 5. Drive one clip all the way in and the other half way in. Set hinge jamb with clips in place over pin and drive protruding clip into place, which secures hinge jamb to hinge rail.

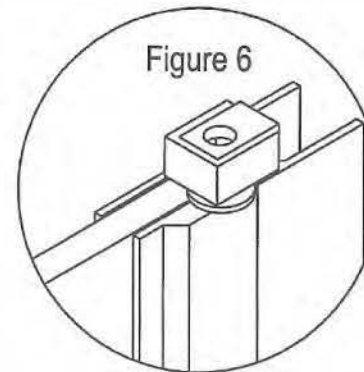

Figure 6

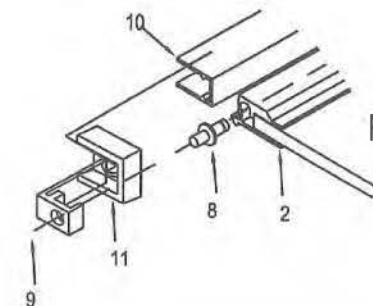
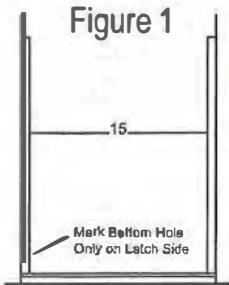

Figure 5

**General:** Well channels (15) are supplied 67 3/4" long. For door only installation (with no header or curb), cut with a hacksaw to 66 5/8" so they will not extend above the hinge and latch jambs.



1. Hold wall channels (15) in a plumb position and mark hole locations on the hinge side and bottom hole only on the latch side (See Figure 1). Drill holes in wall (using 3/16" carbide drill for tile walls). Insert wall anchors (16) into drilled holes.

2. Set wall channels in place and secure with #8 x 1 1/2" screws (17) using bottom screw only on latch side (See Figure 2).

**Note:** Door is adjustable up to 1" (1/2" at hinge jamb and 1/2" at latch jamb).

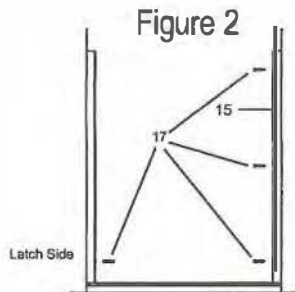

**Example:** A CD-24 door will fit an opening 24" to 25". The 1/2" adjustment should also be used to correct out-of-plumb conditions. For openings up to 24 1/2", set hinge jamb all the way over the wall channel and adjust latch jamb to meet door. For openings over 24 1/2" adjust hinge jamb out on wall channel to compensate for additional opening width.

3. Set latch jamb (18) in place over wall channel, but **Do NOT Secure**.

4. Set hinge jamb with door attached (2 & 11) in place over wall channel. Adjust laterally, plumb to fit opening. Mark three holes on wall channel through the predrilled holes on hinge jamb. Drill three holes with a #31 drill bit and secure with #6 x 3/8" SMS screws (21).

5. Apply 3" vinyl channel (19) to edge of glass, centered on handle side. Tap handle (20) in place over vinyl channel.

6. Align latch jamb (18) with edge of door glass and mark wall channel (15) location on wall. Remove latch jamb and mark holes on wall. Lean wall channel to one side to allow enough room for drill and drill the remaining two holes on wall. Insert wall anchors (16).

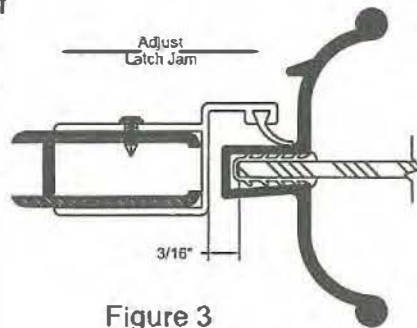

Figure 3

7. Replace wall channel and secure remaining two holes in wall channel using two #8 x 1 1/2" screws (17).

8. Replace latch jamb over wall channel. Close door and adjust latch jamb 3/6" from edge of glass (See Figure 3). Through the holes provided in the latch jamb, drill three #31 holes in wall channel. Secure latch jamb to wall channel with #6 x 3/8" SMS screws (21).

9. Set catch (22) in place on latch jamb (18) and secure with 6-32 x 3/16" screws (23).

10. Adjust drip trough (7), up at latch side of door and down at hinge side of door so water will drain into shower when door is opened. Adjust splash vinyl (6) to within 1/8" of curb.

**Note:** Splash vinyl should not touch curb.

11. Clean area to where sealant is to be applied and run a bead of sealant full length inside and outside of each wall channel, where channel meets wall. Allow sealant to cure for 24 hours.

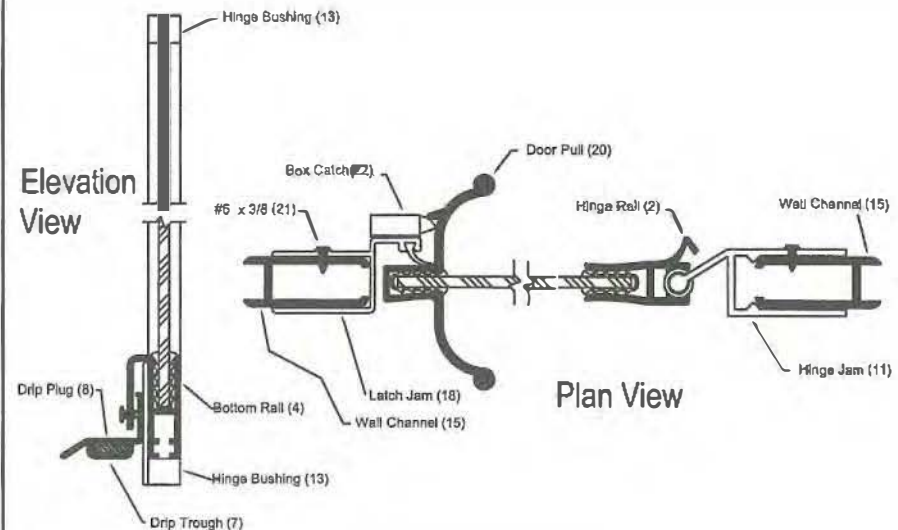



# EUROVIEW

FRAMELESS GLASS ENCLOSURES

## Installation Instructions

Model **MST-90-38/48**

### Continuous Hinge Shower Enclosure

When ordering repair parts, please give the following information:

1. Model Number
2. Part Number
3. Part Description
4. Color

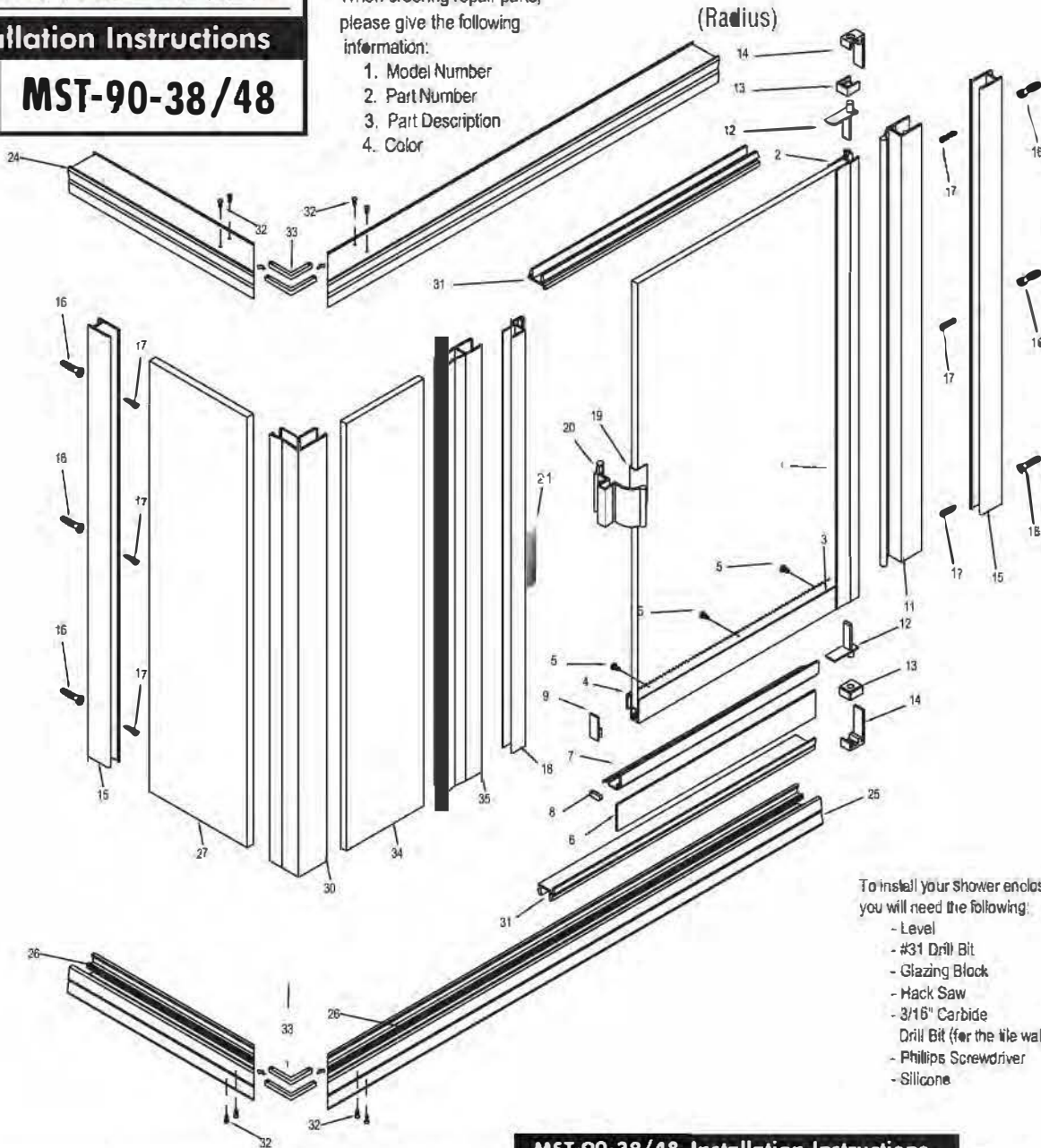

- To install your Shower enclosure, you will need the following:
- Level
  - #31 Drill Bit
  - Glazing Block
  - Hack Saw
  - 3/16" Carbide Drill Bit (for the tile walls)
  - Phillips Screwdriver
  - Silicone

Description	Qty	Part No.	Picture
1. 5" Glazing Vinyl for Hinge Rail	1	ZV-925	
2. Hinge Rail with Vinyl	1	ZD-2503	
3. Glazing Vinyl for Bottom Rail	1	ZV-903	
4. Bottom Rail	1	ZD-1002	
5. #6 x 3/16" Screws	3	B/32 X 3/16	
6. Splash Vinyl	1	ZV-904a	
7. Drip Trough	1	ZD-1008	
8. Drip Plug	1	ZV-905	
9. Bottom Rail End	1	ZV-948	
10. Hinge Jamb Sleeve	1	ZV-355	
11. Hinge Jamb	1	ZD-2505	
12. Hinge Pins	2	ZV-945	
13. Hinge Bushings	2	ZD-1013	
14. Hinge Clips	2	ZD-1009	
15. Wall Channels	2	ZD-1006	
16. Wall Anchors	6	ZV-935	
17. #8 x 1 1/4" Screws	6	#8 x 1 1/4"	
18. Latch Jamb w/ V-908 Vinyl	1	ZD-1004	
19. 3" Handle/Vinyl	1	ZV-914	
20. 3" Pull handle			
21. Magnetic strip clasp			
24. Headers-Mitered 45 Degrees (Radius)	2	ZSS-2101	
26. Curbs-Mitered 45 Degrees	2	ZSS-3101	
26. Glass Support Blocks	3	ZV-902	
27. 90-Degree Glass Panel	1		
28. Vertical Seal Vinyl	8	ZV-909	
29. Horizontal Seal Vinyl	8	ZV-906	
30. 90-Degree Corner Post	1	ZSS-1104	
31. Header and Curb Filers	2	ZSS-1102	
32. #8 x 3/8" Screws	14	#8 x 3/8"	
33. 90-Degree Header/Curb Clips	4	ZC-90	
34. In-Line Glass Panel			
34. In-Line Post	1	ZSS-1103	

Note: Wall channels (15) used in stall shower installation are shipped with the shower door. Read both Door and Stall instructions before starting installation.

1. Add 1/2" to centerline measurements for outside dimension of curb (25). Cut to length. Mark location of curb on threshold with pencil so that curb may be placed back in same position later on.

2. Assemble header (24) and curb (25) using two 19/64 90-degree clips (33) into header and two clips (33) in curb. Using holes provided in header and curb. Then secure using eight #6 3/8" Screws (32). See Figure 1.

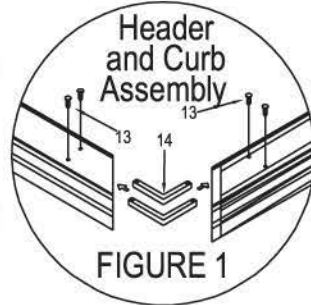

3. Leave curb in place temporarily. Set wall channels (15) into recess in curb. Hold plumb and mark for screw holes. Remove wall channels and curb. Drill 3/16" holes in wall using a 3/16" carbide tipped drill bit. Insert plastic screw anchors (16) into holes. Run a 1/4" round bead of silicone to the full length of the underside of curb, across miters, screw clips and fill each end of curb with silicone where curb will meet wall. Also silicone joint where curb or pan curb meets vertical wall (in the area that will later be covered by metal curb).

4. Replace curb on threshold and apply silicone INSIDE OF CURB at miters, on the top of curb screws and at both walls. Replace wall channels and secure to walls using #8 X 1 1/2" screws (17).

5. Insert two glass support blocks (26) in curb and set 90-degree panel glass (27) in place in curb and wall channel (smooth side of glass to inside). Hold panel in place by starting approximately six inches of the vertical seal vinyl (28) into the wall channel at top of the glass panel, both inside and out. Adjustments for out-of-plumb walls are accomplished by the movement of glass panel in and out of channels. For proper installation of vinyl for water tightness, the glass must extend at least 1/4" into channels.

6. Set corner post (30) in place over glass and into curb (fluted side of post next to the panel glass). Hold post in temporary position by securing at top with vertical seal vinyl (28) and at bottom by securing post to curb with #6 X 3/8" (21) on inside of curb on the door side.

7. Insert glass support block (26) in curb where in-line glass panel (34) will go.

8. Set in-line glass panel (34) in place (smooth side of glass to inside) and move all the way into corner post (30). Tack in place at top only with vertical seal vinyl (28).

9. Set in-line post (35) in position (Fluted Side Toward Fixed Panel) and move as far onto glass as possible. Tack in place at top with wall channel vinyl. To get door and panel to fit opening, your unit has 1" adjustment in fixed panel and 1" adjustment in door. 1/2" maximum at each point. Most installers prefer to take the maximum adjustment out of the stationary panel and the remainder out of the door. There are two things to consider when determining these adjustments. First, the glass of the fixed panel must go into the corner post and in-line post at least 1/4" at both sides. This is to ensure that the vinyl will hold the glass properly and provide adequate water protection. A good way to remember this is that the distance between the corner post and in-line post

on stationary panel side can never be narrower than panel size minus 1 1/2" and never wider than panel size minus 1/2". For example: A 10" panel = 8 1/2" minimum distance and 9 1/2" maximum distance. Second, the opening for the door must be adequate. The curb and header filler (31) will help you determine this. Minimum length for header filler is door size minus 1 7/8" and the maximum length is door size minus 7/8". For example, for a D-1000-24, the minimum length of curb or header filler is 22 1/8" and the maximum length is 23 1/8". However, if the adjustable latch jamb is used add 3/16" to these measurements, making the minimum length of curb and header filler for D-1000-24 = 22 5/16" and maximum length = 23 5/16".

10. Temporarily set in-line post (35) so that the distance between wall channel on door side and in-line post is at least the minimum measurement for the curb filler. For example, a standard CD-24 = 22 1/8" (a CD-24 w/ adjustable latch jamb = 22 5/16"). Now check the plumb of the wall on the door side. If wall is leaning in towards the center 3/8" then this 3/8" must be added to the length of the curb filler. If the wall is leaning out, away from the center, the curb filler remains the same and the out condition measurement is added to the header filler measurement (Provided the measurement doesn't exceed the maximum.). Move In-Line post accordingly.

11. Now check panel side measurements to be sure you are within the tolerances at both top and bottom. If the measurements are good, cut curb filler (31) to size and install with the 1/8" raised lip to the outside. If the panel size measurements are not good, move in-line post accordingly, remembering that you have four places to adjust; at the hinge side, the latch side and both sides of the fixed panel. Header and curb filler should always fit tight between the wall channel and in-line post, both at the top and at the bottom.

#### Refer to CD Shower Door Installation instructions for door assembly.

12. Set door (with hinge jamb attached) over wall channel using adjustments derived from Step #10. Door with hinge clip should be resting on TOP of curb filler (31). Use a #31 drill bit and #6 X 3/8" (21) to secure hinge jamb to wall channel.

13. Apply the 3" ZV-914 vinyl (19) on handle edge of door glass. Top of vinyl should be 1 1/2" above center. Tap on handle (20).

14. Pull in-line post (35) over until it butts to curb filler (31) at bottom.

15. Snip excess vinyl from latch jamb vinyl (18), crimp at bottom and place latch jamb over in-line (35), but DO NOT SECURE.

16. The heat treating of the glass sometimes causes the glass to bow. To insure water tightness at the latch, it is important to get the latch jamb to follow the bow in the glass as closely as possible. Because door closes against latch jamb and in-line post which are not held firmly in place with header at this time. It is necessary to substitute your 4 ft. level or straight edge to align door wall channel and in-line post with latch jamb and corner post until header lengths are determined.

17. Stand inside shower and hold the straight edge on outside of wall channel, in-line post and 90-degree corner post above door. Holding them in line, pull door closed and align to latch jamb by moving the 90-degree corner post (30) in and out at top of the 90-degree panel (27).



**18.** Step #17 determines the length of the header (24) over the in-line panel (34). DO NOT MOVE FROM THIS POSITION ON STATIONARY PANEL GLASS. Now plumb the corner post to the door side wall and measure the distance from both walls to the outside edge of corner post. Add 1/4" to these measurements and you have the outside dimension to your header. Cut to size.

**19.** Place header (24) into position over wall channels (15), corner post (30) and in-line post (35). Recheck alignment of door at latch jamb. If alignment is still good, move in-line post tight against your curb filler at the bottom. Plumb and measure header filler (31). Cut header filler and snap into place in the header with the 1/8" lip to outside.

**20.** Secure headers to wall channel on stationary panel side with #6 X 3/8" (21) on inside of header. Before securing header over door, make header parallel with top of door by moving it up or down at either wall channel or corner post. Once this is done secure header to wall channel, in-line post and corner post with #6 X 3/8" on inside of the header. Secure in-line post and 90-degree corner post to curb in same fashion.

**21.** Complete the installation of vertical seal vinyl (28) in wall channel and corner post.

**22.** Install horizontal seal vinyl (29) at top and bottom of stationary panel both inside and out.

**23** Recheck alignment of door and corner post. If installation of vinyl into corner post has pushed corner post out of alignment, realign by tapping corner post back or forth on stationary panel until it is realigned.

**24.** Adjust latch jamb (18) for good fit (normally 3/16" clearance from edge of door to latch jamb is perfect, see Figure 2). Now secure with #6 X 3/8" (21).

**25.** Set magnet (22) in place on latch jamb and secure with 6-32 X 3/16" (23) in holes provided at center of latch jamb.

**26.** Adjust drip trough (7), up at latch side of door and down at hinge side of door so water will drain into shower when door is opened. Adjust splash vinyl (6) to within 1/8" of curb. **IMPORTANT:** Splash vinyl should never be in direct contact with curb! A 1/8" space should exist between vinyl and curb.

**27.** Silicone along inside and outside edge of metal and tile.

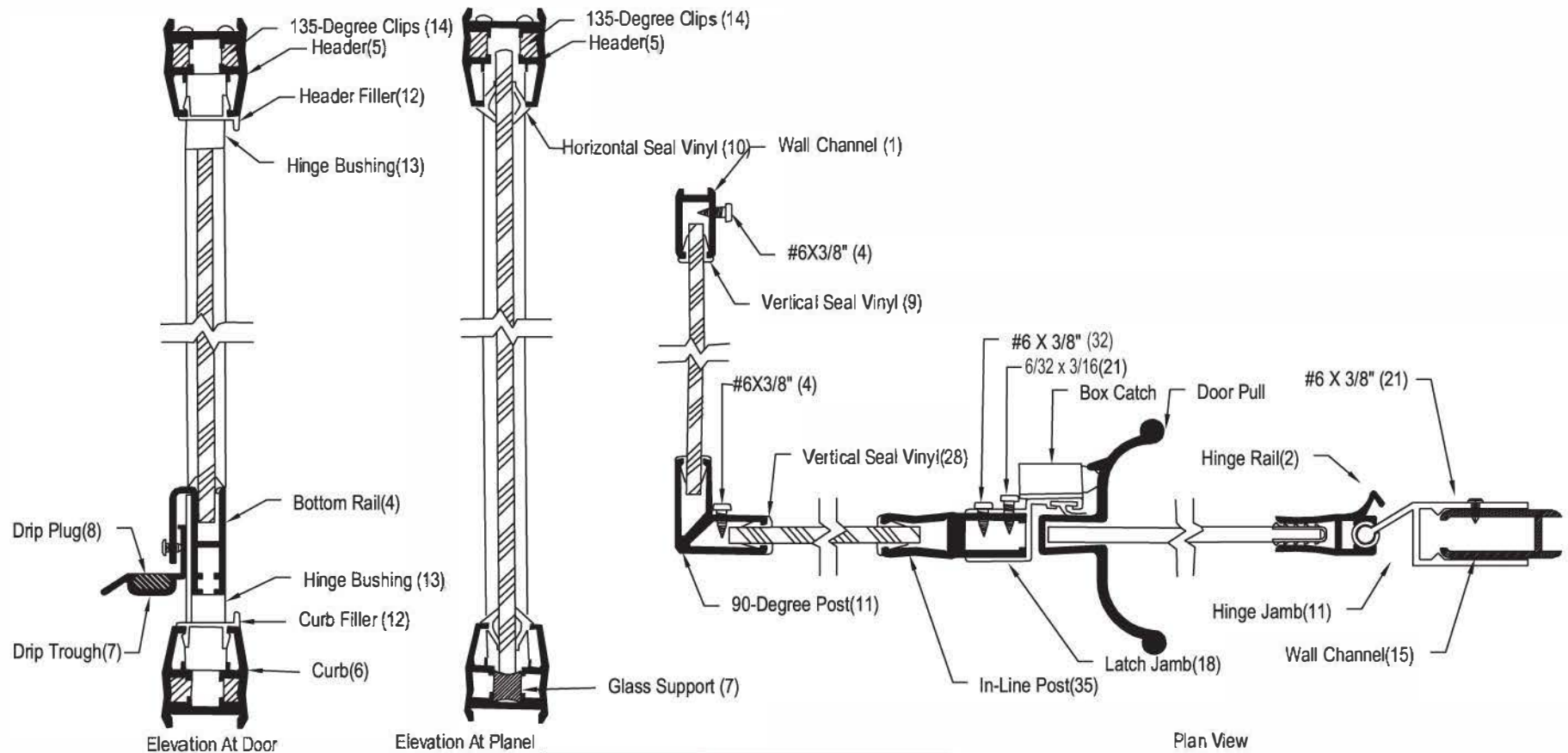



FRAMELESS GLASS ENCLOSURES

### Installation Instructions

Model **MST-90-38/48**

### Buttress Application

